

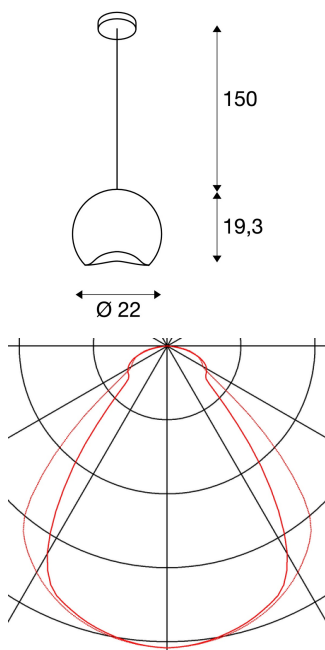

PLASTRA PD-1 pendant

LED GX53, white plaster, 9 W

With the plaster lamp PLASTRA PD-1, you own a highly individual up/down wall luminaire with puristic and clear design. Prepared for the use of two GX53 halogen or LED retrofit lamps, PLASTRA is ready for direct connection to 230V mains supply. Some sandpaper is included in the package and used for surface cleaning. After priming it can easily be painted over with standard wall paint.



TECHNICAL DATA

Item no.:	148040
Socket	GX53
Lamp	TCR-TSE
Number of sockets	1
Lamps included	0
Primary nominal voltage	230V ~50Hz mA/V
Pendant length	150.0 cm
Height	19.3 cm
Diameter	22.0 cm
Net weight	2.645 kg
Gross weight	3.173 kg
IP Code	IP 20
Safety class	I
Assembly	Surface
Assembly details	Ceiling
Wattage	11.0 W
Color	white
BIG WHITE Page	49

Recommended lamp

550092	LED GX53 , lamp, 3x1.4W, warm-white LED, 35° beam angle
551372	LED GX53 , SMD LED, 3W, 3000K, not dimmable

Notes
