

I-LINE TOUCH

floor stand, LED, 3000K, white, acrylic side shade, 1x11W, 10x2,1W

The I-LINE TOUCH floor luminaire is a top-class LED product. The sensor field enables touch dimming and lets you turn side lamps and the top flood on and off with a tap. Individually activated lamps can be dimmed with sustained pressing. The floor luminaire is equipped with a high output, Premium COB LED ceiling flood, and high-grade SMD LEDs in the luminaire body for general room lighting. The I-LINE TOUCH Floor Luminaire comes complete with a power plug. The product is ready to be directly connected to the 230V supply.

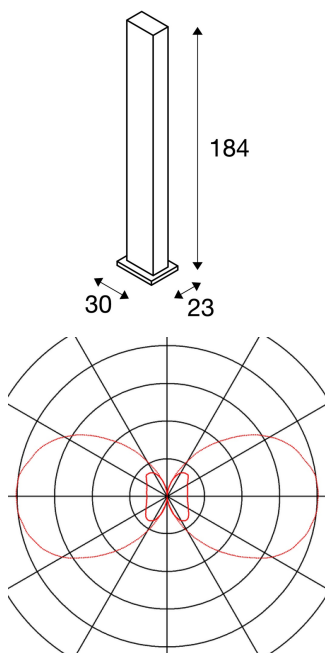

TECHNICAL DATA

| | |
|-------------------------------------|--------------------------|
| Item no.: | 157001 |
| Lamps included | 0 |
| Number of different light outlets | 2 |
| Primary nominal voltage | 100-240V ~50/60Hz mA/V |
| Secondary power / secondary voltage | 12 mA/V |
| Width | 30.0 cm |
| Height | 184.0 cm |
| Depth | 23.0 cm |
| Net weight | 14.427 kg |
| Gross weight | 18.616 kg |
| IP Code | IP 20 |
| Safety class | I |
| Impact resistance class | IK03 |
| Impact resistance | 0,3499999999999998 Joule |
| Assembly | Mobile |
| Wattage | 31.0 W |
| Lumen | 1350 lm |
| Colour temperature | 3000 Kelvin |
| Beam angle | 80 ° |
| Color | white |
| CRI | >80 |
| Binning | 6 |



| | |
|----------------|---------|
| Binning 2 | 6 |
| LXXBXX data | 70/50 |
| Service life | 40000 h |
| Service life 2 | 30000 h |

Notes
