

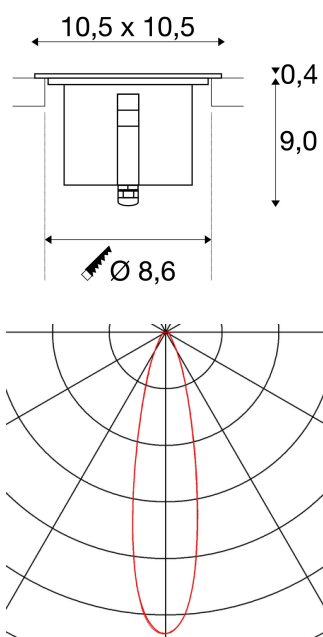

DASAR 100 PREMIUM

outdoor inground fitting, LED, 3000K, IP67, square, stainless steel, 24°, L/W/H 10.5/10.5/9.43 cm, 3.8W

The walk-on and scratch resistant high-voltage inground fitting DASAR 100 PREMIUM with its round stainless-steel bezel and glass cover is fitted with warm-white, high-performance power LEDs. With its IP67 protection class, the luminaire is suitable for outdoor use. The electrical connection is made directly to the 230V mains supply. In addition, the luminaire has high thermal, chemical, mechanical and optical resistance. There are other versions of the luminaire with different beam angles or, alternatively, with a stainless steel housing available. This luminaire contains built-in LED lamps.



TECHNICAL DATA

Item no.:	233702
Lamps included	0
Primary nominal voltage	220-240V ~50/60Hz mA/V
Secondary power / secondary voltage	400 mA/V
Length	10.5 cm
Width	10.5 cm
Depth	9.4 cm
Installation diameter	8.6 cm
Installation depth	13.4 cm
Net weight	1.127 kg
Gross weight	1.228 kg
IP Code	IP 67
Safety class	I
Impact resistance class	IK08
Impact resistance	5 Joule
Assembly	Recessed
Assembly details	Ground
Wattage	5.5 W
Lumen	300 lm
Colour temperature	3000 Kelvin
Beam angle	24 °
Color	stainless steel

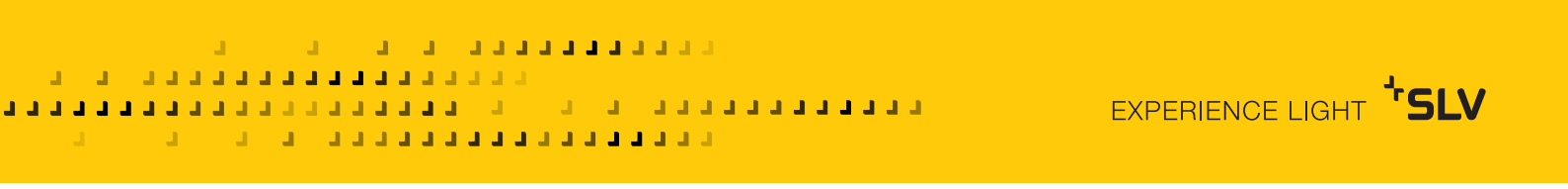

Accessories

228726	T-CONNECTIONBOX , black, IP68
--------	-------------------------------

CRI	>80
Binning	6
LXXBXX data	70/50
Service life	30000 h
Maximum ambient temperature	40 °C
Mechanical loading	2 t

Notes
